

MAINTENANCE INSTRUCTIONS

Use these instructions to clear label jams in your Monarch® 9415™ Food Freshness System.

Caution: These instructions are for **managers only**. Removing the platen roller could void your warranty.

Do not use sharp objects to remove jammed labels from the supply slot or the platen roller. This damages the roller and voids the warranty.

Removing the Platen Roller

1. Turn off the printer.
2. Lift the printer from the wall and place it on a table or other flat surface.
3. Tear off any labels in the supply slot, then open the supply door and remove the roll of labels. Do not pull labels backwards through the supply slot. This causes jams.
4. Remove the supply holder guides from the supply holder.
5. Use a Phillips screwdriver to remove the four screws from the printhead cover.

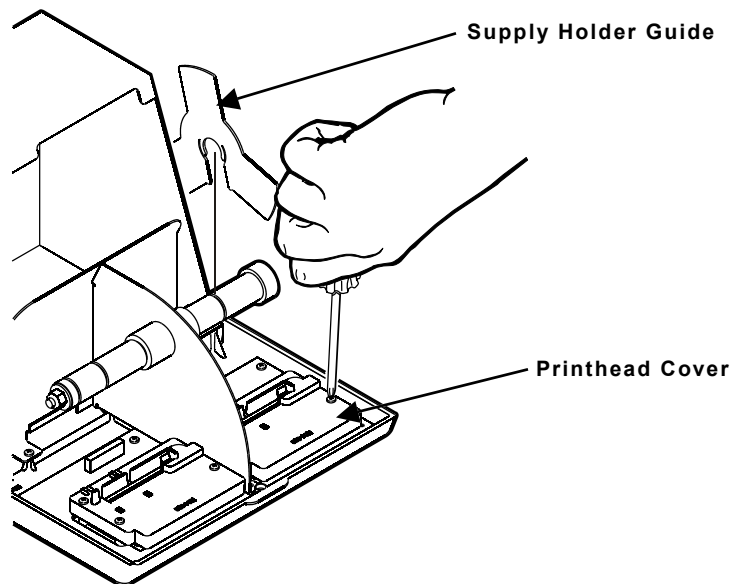

6. Lay the printhead cover to the side. Do not detach the sensor cable.

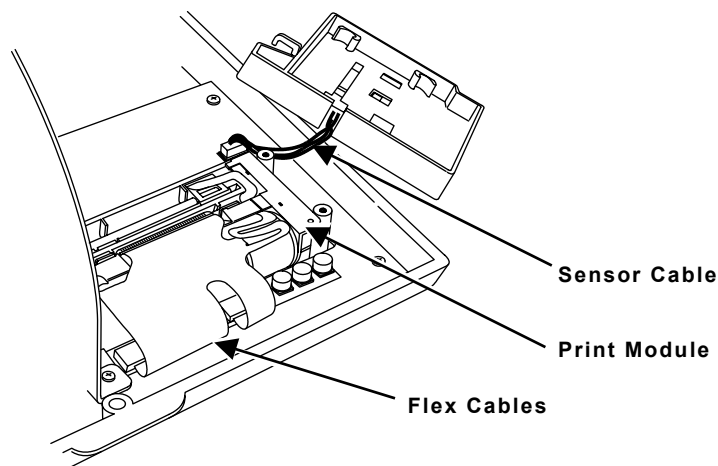

7. Carefully lift the print module and rotate it toward you so the platen roller faces up. Be careful not damage or remove the flex cables.

Note: The print module stays attached to the printer.

8. Press down on the lever on the right-hand side of the platen roller until the platen roller pops out of the print module.

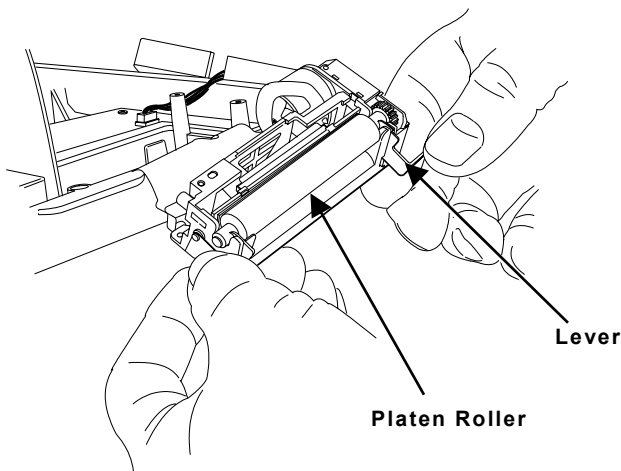

Cleaning & Clearing Jams

1. Use your fingers to remove any labels wrapped around the platen roller.

Note: Do not use sharp objects to remove labels from the platen roller. This damages the roller and voids the warranty.

2. Clean any adhesive buildup from the platen roller using a dry, soft-bristle brush, such as a toothbrush, or a cotton swab moistened with isopropyl alcohol.
3. Use the brush to clean any paper dust from the print module.
4. Use a cotton swab moistened with isopropyl alcohol to clean the printhead. Allow the printhead and the platen roller to dry before re-installing the platen roller.

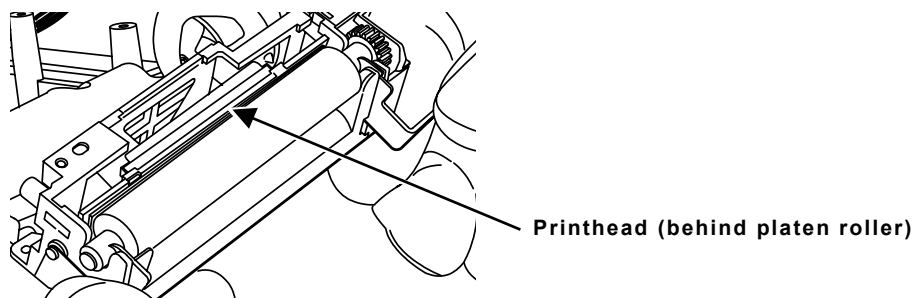

Re-Installing the Platen Roller

1. Place the platen roller back into the print module so the gear is on the right-hand side. Push gently until the roller snaps into place.
2. Lay the print module back into cavity on the supply door. Be careful not to damage or remove the flex cables.
3. Replace the printhead cover and screw it into place. Do not over-tighten the screws.
4. Replace the supply holder guides and reload the labels.
5. Remount the printer on the wall and close the supply door.

Technical Support

Call Service for additional assistance or to order a replacement platen roller (order part number 12703158).